

SDMO K9

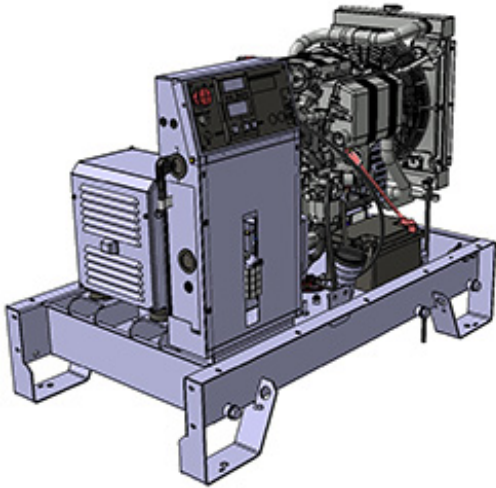

GENERAL SET DATA

ENGINE REF:	KDW1003
ALTERNATOR REF:	KH00260T
STANDARD CONTROL PANEL:	APM303
OPTIONAL CONTROL PANEL:	TELYS

OUTPUT

FREQUENCY:	50 Hz
VOLTAGE:	400/230
PRIME POWER:	8.1 kVA
STANDBY POWER:	8.9 kVA

DIMENSIONS

OPEN MODEL

LENGTH:	1220 mm
WIDTH:	700 mm
HEIGHT:	920 mm
DRY WEIGHT:	290 Kg
FUEL TANK CAPACITY:	50 L

CLOSED MODEL

LENGTH:	1482 mm
WIDTH:	760 mm
HEIGHT:	1030 mm
DRY WEIGHT:	390 Kg
FUEL TANK CAPACITY:	50 L
ACOUSTIC PRESSURE AT 1M:	67 dB
ACOUSTIC PRESSURE AT 7M:	54 dB

SDMO K9

TECHNICAL DATA

GENERAL ENGINE DATA

MANUFACTURER:	KOHLER
MODEL REF:	KDW1003
SPEED:	1500 RPM
POWER PRP:	6.5 kW
POWER LTP:	7.1 kW
NUMBER OF CYLINDERS:	3
DISPLACEMENT:	1.03 L
BORE:	75 mm
STROKE:	77.6 mm
COMPRESSION RATIO:	22.8
COOLING SYSTEM:	GLYCOL-ETHYLENE
AIR INLET SYSTEM:	ATHMO
OIL CAPACITY:	2.4 L
EXHAUST GAS TEMP:	440 °C
EXHAUST GAS FLOW:	30.7 L/s

ALTERNATOR DATA

ALTERNATOR REF:	KH00260T
INSULATION CLASS:	H
INDICATION OF PROTECTION:	IP23

FUEL

CONSUMPTION AT 100%:	2.5 L/hr
CONSUMPTION AT 75%:	1.9 L/hr
CONSUMPTION AT 50%:	1.3 L/hr

TERMS & CONDITIONS

PRP : Prime Power is available for an unlimited number of annual operating hours in variable load applications, in accordance with ISO 8528-1. ESP : The standby power rating is applicable for supplying emergency power in variable load applications in accordance with ISO 8528-1. Overload is not allowed.

According to the standard, the nominal power assigned by the genset is given for 25°C Air Inlet Temperature, of a barometric pressure of 100 kPa (100 m A.S.L), and 30 % relative humidity. For particular conditions in your installation, refer to the derating table.